

How To Make Bugle Puffed Snack Automatically?

Detail Introduction :

Introduction Of Bugle Puffed Snack Making Machine:

The machine typically consists of several different components, including a dough mixer, a dough sheeting system, a cutting and shaping station, and a frying or baking unit. The process begins by mixing a dough from a combination of cornmeal, wheat flour, water, and other ingredients. The dough is then sheeted and cut into individual Bugle shapes, which are then either fried or baked to achieve the desired crispy texture. The Bugles snack making machine is capable of producing Bugles in a wide range of sizes and flavors and can be customized to meet the specific needs of individual manufacturers. This equipment is commonly used in large-scale food production facilities, where high volumes of snacks are produced on a daily basis.

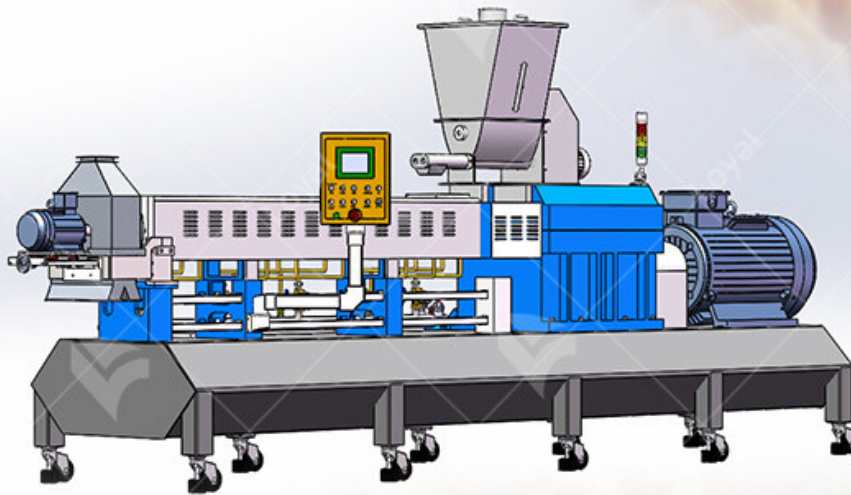

The Bugle Puffed Snack Production Line Details

Capacity	150kg-350kg
Power Supply	Based on 380V 50 Hz 3 phase. Customized according to your local power.
Machine details	1.Stainless steel,:201, 304, 316, on request 2. Electric parts can be ABB, Delta, Fuji, Siemens; Famous brand as your demand.
Certificate	CE,GOST,TUV,BV
Raw Material	Wheat flour, corn, rice, oat, etc.

Products Color	White, Yellow
Products type	Crispy chips,Sala,Bugles,Sticks.etc.

Flow Chart Of Commercial Bugle Puffed Snack Processing Line:

Mixing Extrusion Cutting Frying or Baking Seasoning Cooling Packaging

The Equipment Using In The Bugle Puffed Snack Making Machine:

Mixer--Screw Conveyor--Twin Screw Extruder--Pulling And Cutting Machine--Continuous Fryer--Deoiling

Machine--Flavoring Machine

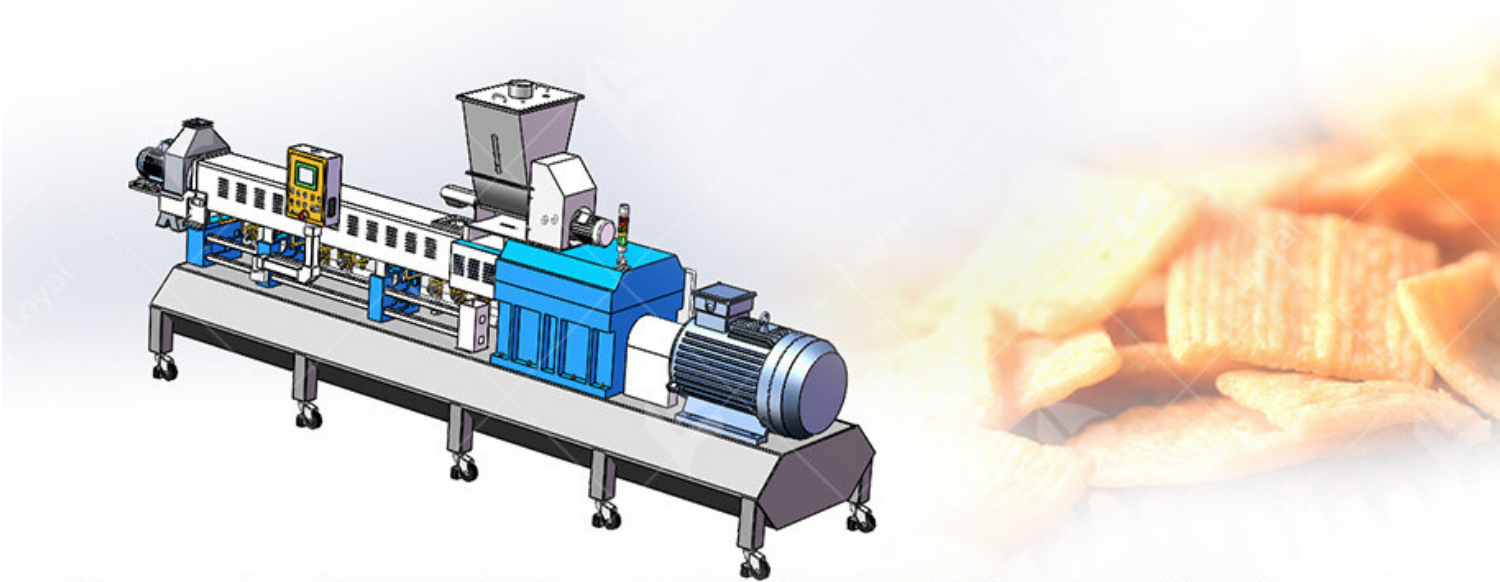

Feature Of Bugle Puffed Snack Machines:

- 1.Dough Mixer: Bugles snack machines typically include a dough mixer that can mix the various ingredients needed for the dough at a high volume and speed.
- 2.Extrusion Die: The machine also includes an extrusion die, which is responsible for shaping the dough into the signature horn shape of Bugles snacks.
- 3.Cutting and Shaping Station: Once the dough has been extruded into the desired shape, the machine includes a cutting and shaping station that can quickly and accurately cut the Bugles into individual pieces.
- 4.Frying or Baking Unit: The Bugles are then fried or baked to achieve the desired crispy texture.
- 5.Seasoning System: After cooking, the Bugles are seasoned with various flavors, such as cheese or ranch.
- 6.Cooling Conveyor: The Bugles are then cooled to room temperature on a cooling conveyor to prevent them from becoming too hot and losing their crispy texture.
- 7.Quality Control: Throughout the processing line, quality control checks are performed to ensure the

meet the desired specifications for taste, texture, and appearance.

8. Customization Options: Bugles snack machines can often be customized to meet the specific needs of individual manufacturers.

Parameter Of Bugle Puffed Snack Machine:

Model	Installed capacity	Power	Output capacity	Size (L*W*H)
DH65	88KW	65KW	150-200kg/h	18000x2000x4000mm
DH70	126KW	82KW	200-250kg/h	22000x2000x4000mm
DH70L	126KW	82KW	250-350kg/h	26000x2000x4000mm

Machine Photos Of Bugle Puffed Snack Production Line

Machines Materials: All the machines are made by stainless steel.

Applications Of Bugle Puffed Snack Production Line:

1. Automated Production: A bugles snack production line can automate the production process, from the ingredients to shaping and frying the bugles.

2. Consistent Quality: A bugles snack production line can produce bugles with consistent quality, texture, and flavor.

3. Customization: A bugles snack production line can be customized to produce different flavors, shapes, and sizes of bugles. This can help companies to cater to the specific tastes and preferences of their target market.

4. Food Safety: A bugles snack production line can incorporate various food safety measures to ensure that the snacks are free from contamination and meet the required health standards.

5. Scalability: A bugles snack production line can be scaled up or down depending on the demand for the product.

Overall, a bugles snack production line can help companies to produce bugles snacks efficiently, consistently, and safely, while also allowing for customization and scalability.

